



# Installation Manual Double -DIN Kit

**black: 381320-30-1**

**piano-black: 381320-30-2**

**rubber-touch: 391320-30-1**

## SEAT

Seat Alhambra (7N) 10/2010 ->  
 Seat Leon (1P/1PN) 03/2009 - 10/2012  
 Seat Toledo (KG) 03/2013 >

## SKODA\*

Skoda Fabia (5J) (4/5 Türen / 4/5 doors) 03/2007 -> \*  
 Skoda Fabia (5J) Combi 10/2007 > \*  
 Skoda Octavia II (1Z) Facelift  
 Limousine/Combi 01/2009 - 02/2013 \*  
 Skoda Octavia II (1Z) Facelift Scout 01/2009 ->  
 04/2012 \*  
 Skoda Rapid (NH) 10/2012 -> \*  
 Skoda Roomster (5J) 09/2006 -> (OEM-Radio) \*  
 Skoda Superb (3T) Limousine 07/2008 > \*  
 Skoda Superb (3T) Combi 01/2010 > \*  
 Skoda Yeti (5L) 08/2009 > \*

\*= under certain circumstances a Skoda  
 OEM bezel may be required

## VOLKSWAGEN

VW Amarok (2H) DoubleCab 03/2010 ->  
 VW Amarok (2HS2) SingleCab 11/2011 ->  
 VW Beetle (16) 11/2011 ->  
 VW Beetle (16) Cabrio 11/2012 ->  
 VW Caddy (2K) 10/2003 ->  
 VW CC (3CC) 01/2012 ->  
 VW Eos (1F) 05/2006 ->  
 VW Golf V (1K) 10/2003 - 09/2008  
 VW Golf V Variant (1KM) 06/2007 - 10/2009  
 VW Golf V Plus (1KP) 03/2005 -> 02/2009  
 VW Golf VI (1K) 11/2008 - 12/2012  
 VW Golf VI Variant (1KM) 11/2009 - 04/2013  
 VW Golf VI Cabrio (1K) 06/2011 ->  
 VW Golf VI Plus (1KP) 03/2009 - 01/2014  
 VW Jetta V (1KM) 09/2005 - 10/2010  
 VW Jetta VI (16) 01/2011 ->  
 VW Passat B6 (3C) 11/2005 - 07/2010  
 VW Passat B6 (3C) Variant 08/2005 - 07/2010  
 VW Passat B7 (3C)  
 Limousine / Variant 11/2010 ->  
 VW Passat B7 (3C) Alltrack 01/2012 ->  
 VW Passat CC (3C/3CC) 05/2008 -> 01/2012  
 VW Polo (6R) 06/2009 - 03/2014  
 VW Scirocco III (13) 08/2008 ->  
 VW Sharan II (7N) 09/2010 ->  
 VW Tiguan (5N) 09/2007 ->  
 VW Touran (1T) 02/2003 ->  
 VW T5 Multivan "Startline"  
 (7HM/7HN/7HF/7EF/7EM/7EN) Facelift  
 09/2009 ->  
 VW T5 Transporter/Pritsche  
 (7JD/7JE/7JL/7JY/7JZ) Facelift 09/2009 ->

## Compatible with double DIN devices

### Double-DIN navigation

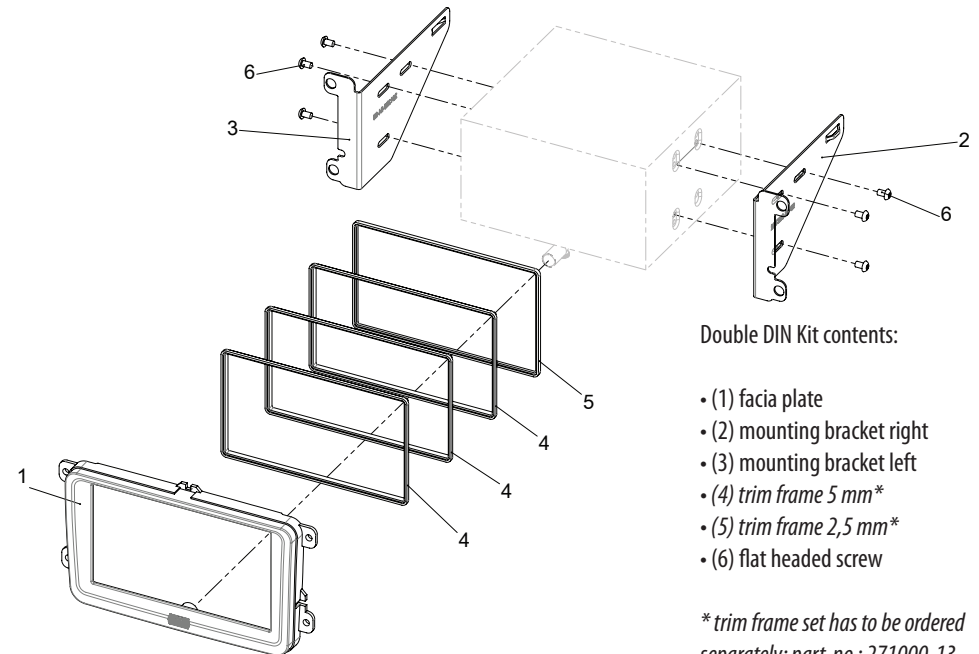

Double DIN Kit contents:

- (1) facia plate
- (2) mounting bracket right
- (3) mounting bracket left
- (4) trim frame 5 mm\*
- (5) trim frame 2,5 mm\*
- (6) flat headed screw

\* trim frame set has to be ordered  
 separately: part-no.: 271000-13

All installation work must be performed by a qualified professional installer only.  
 The manufacturer / dealer is not liable for any kind of incidental or indirect damages.  
 Technical changes possible. All rights reserved.

(c) 2014 · ACV GmbH · Straßburger Allee 10-12 · 41812 Erkelenz



2. Remove the original trim frame, surrounding the radio (fixed by clips)



3. Remove all 4 Torx (TX20) screws (These screws will be used again later)

Remove OEM head unit

Follow instructions on page 10

---

---

---

---

---

---

---

---

---

---

---

---

---

---

---

---

---

---

---

---

---

---

---

---

## Radio installation

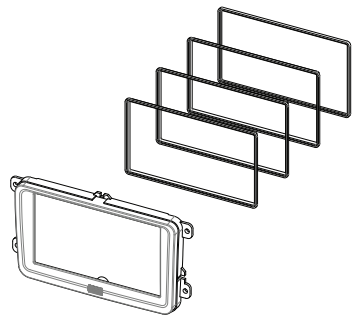

1. Depending on the double DIN head unit you want to install stick the appropriate trim frame(s)\* to fascia plate and fix them with glue

**\* trim frame set has to be ordered separately: part-no.: 271000-13**

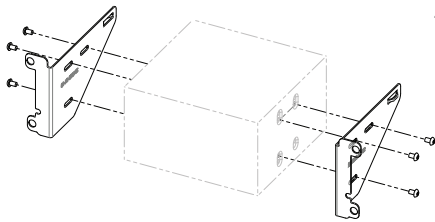

2. Mount metal brackets to double DIN head unit

Connect all required circuit points and push double DIN head unit into dashboard

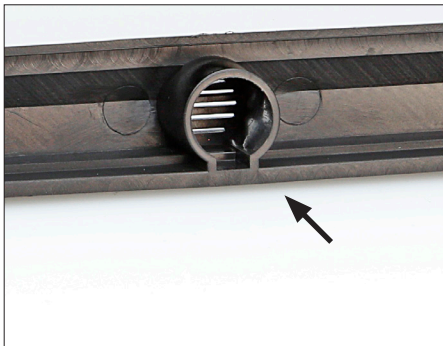

3. (Optional: install microphone in pocket of the backside of fascia plate)



4. Push fascia plate over double DIN head unit and fix it with original Torx (TX20) screws

Reinstall everything in reverse order to finish installation.

## VW Golf V



1. Pull up upper shelf (fixed by clips). Remove both screws underneath the shelf (see arrows)



2. Remove the original trim frame, surrounding the radio (fixed by clips)



3. Remove all 4 Torx (TX20) screws (These screws will be used again later)

Remove OEM head unit

Follow instructions on page 10



1. Unclip and remove OEM panel



2. Remove all 4 Torx (TX20) screws  
*(These screws will be used again later)*



3. Remove OEM head unit

Follow instructions on page 10



1. Unclip and remove OEM panel  
*(see arrows)*



2. Remove all 4 Torx (TX20) screws  
*(These screws will be used again later)*

Remove OEM head unit

Follow instructions on page 10



## Seat Alhambra / VW Sharan

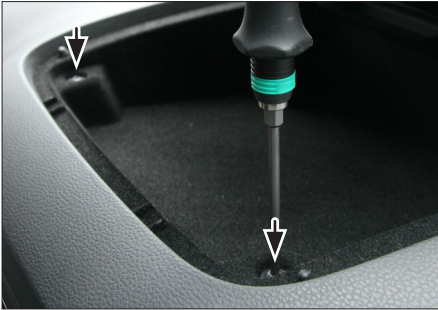

1. Open top shelf  
Remove both screws



2. Remove top shelf inlay  
Remove both screws



3. Remove the original panel surrounding the radio  
(fixed by clips)



4. Remove all 4 Torx (TX20) screws  
(These screws will be used again later)

Remove OEM head unit

Follow instructions on page 10

## VW Tiguan



1. Unclip and remove OEM panel  
(see arrows)



2. Remove all 4 Torx (TX20) screws  
(These screws will be used again later)

Remove OEM head unit

Follow instructions on page 10



1. Unclip and remove upper shelf

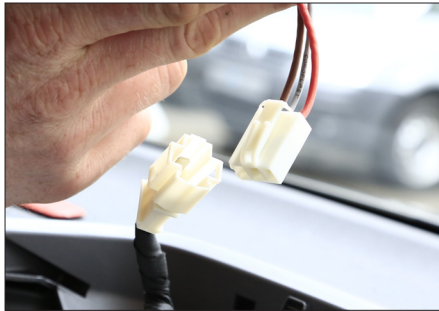

2. Disconnect plugs of the 12V female connector carefully



3. Remove both screws at the upper trim of the upper shelf opening



3. Remove both blanking plugs left and right beside the the OEM head unit



4. Remove all screws under the blanking plugs (see arrows)



5. Unclip front panel and unplug all cables carefully  
Remove front panel



6. Remove all 4 Torx (TX20) screws (These screws will be used again later)

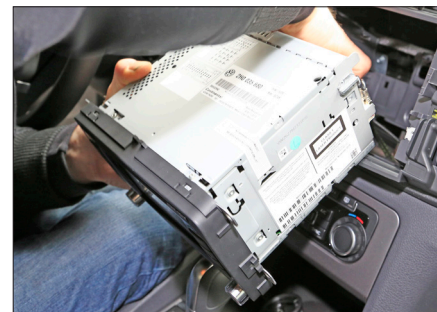

7. Remove all plugs carefully  
Remove OEM head unit  
Follow instructions on page 10